

WISCONSIN CENTER DISTRICT 2017 EXHIBITOR SERVICES ORDER FORM

Advance prices apply only to orders received by the WCD at least 14 days prior to the 1st day of the event scheduled exhibitor move-in.

Owners and Operators of the Wisconsin Center - UW-Milwaukee Panther Arena - Milwaukee Theatre

Mailing Address: Wisconsin Center District - 400 West Wisconsin Avenue - Milwaukee, WI 53203-2104
www.wcd.org - Main Tel.: (414) 908-6000 - Fax: (414) 877-0995 - Exhibitor Services: (414) 908-6053 - Email: ExhibitorSvc@wcd.org

Name of Event: _____ Date(s) of Event: _____
 Firm Name: _____ Location / Booth #: _____
 Address, City, State, Zip: _____
 Contact: _____ Phone: _____ Email: _____

A. Electrical

Custom Service Labor/Materials: male plug conversions, hard wiring connections, 3 or more outlets, booth to booth cable runs, 3 phase, overhead power, relocation of installed cables, retapping transformer from foreign to domestic, or lift rental. Material charges or Electrician's discretion may result in higher charges. Limited availability: 480v and other amps/volts; call for pricing.

Prices are per event cost.					
Qty	Description	Advanced	Standard	Amount	24 hr.
_____	1600w (Standard 20 amp 120v)	\$155.00	\$230.00	_____	<input type="checkbox"/>
_____	Power Strip (6 plug-order)	\$32.00	\$42.00	_____	
_____	Extension Cord (25 ft.)	\$32.00	\$42.00	_____	

If ordering a power strip or extension cord standard 1600w has to be ordered.

A plug conversion by WCD is \$50.00 for 10-30 amps, 208v, 1 or 3 phase, and no additional cost when you bring in a standard male NEMA L21-30P on your equipment pigtail. Hardwired connections using WCD pigtails will cost an additional \$110.00. All 480v connections will be hard wired by the WCD. Items not returned will be billable.

_____	10-20 amp 208v 1 phase	\$260.00	\$310.00	_____	<input type="checkbox"/>
_____	30-40 amp 208v 1 phase	\$280.00	\$330.00	_____	<input type="checkbox"/>
_____	50-60 amp 208v 1 phase	\$335.00	\$360.00	_____	<input type="checkbox"/>
_____	70-100 amp 208v 1 phase	\$380.00	\$410.00	_____	<input type="checkbox"/>
_____	10-20 amp 208v 3 phase	\$350.00	\$400.00	_____	<input type="checkbox"/>
_____	30-40 amp 208v 3 phase	\$360.00	\$410.00	_____	<input type="checkbox"/>
_____	50-60 amp 208v 3 phase	\$405.00	\$455.00	_____	<input type="checkbox"/>
_____	70-100 amp 208v 3 phase	\$560.00	\$610.00	_____	<input type="checkbox"/>
_____	Amps _____ Volts _____ Phase _____	Call for pricing.			
_____	Electrical Labor	Call for hourly rate.			
_____	24 Hour Power outlet cost: _____	x 0.50			

For other amps / volts not listed, call (414) 908-6053 for pricing. Tax not charged on Electrical Services.

Subtotal Electrical: _____

C. Mechanical

Compressed Air: Supply your own drier or regulator. Labor, lift, and/or material charges may apply for some installs (see attached *Service Conditions & Regulations*). Portable Air Compressors are not allowed on site. WCD does not have metric fittings. All lines are a standard female quick disconnect plus a shut off valve.

Prices are per event cost.				
Qty	Description	Advanced	Standard	Amount
_____	Compressed Air (select size)	\$175.00	\$250.00	_____
_____	1/4" _____ 3/8"	Make sure to check size.		
_____	Compressed Air 1/2"	\$240.00	\$315.00	_____
_____	Gas Line	\$225.00	\$275.00	_____
_____	Water/ Drain (Running Water)	\$300.00	\$345.00	_____
_____	Water (Additional Running)	\$90.00	\$100.00	_____
_____	Water Only (No Drain)	\$195.00	\$22.00	_____
*Water/ Drain (Fill): Each order includes one time water fill & drain up to 500 gallons.				
_____	*Water/ Drain (1 Fill-500 gallons)	\$305.00	\$345.00	_____
_____	Add 1 fill --Each 50 gallons	\$55.00	\$65.00	_____
_____	Engineering Labor	Call for hourly rate.		

Tax not charged on Mechanical Services.

Subtotal Mechanical: _____

B. Information Technology (I.T.)

Please contact the WCD IT Department to discuss any special applications or equipment that will be using internet access to ensure proper programming of internet services: (414) 908-6087.

Prices are per event cost.				
Qty	Description	Advanced	Standard	Amount
_____	Internet (High Speed - per device)	\$250.00	\$300.00	_____
_____	Wireless Internet (Wi-Fi - per device)	\$150.00	\$200.00	_____
_____	Internet Bandwidth (Ultra-high Speed - WEBCAST, special applications, etc.)	Call for pricing. (414) 908-6087		_____
If ordering a phone line, please check the box to the right if you need long distance. Long Dist.				
_____	Phone & Line-Analog (local & 800)	\$150.00	\$200.00	_____ <input type="checkbox"/>
_____	Multi-Line Set with 3 lines (Digital)	\$200.00	\$250.00	_____ <input type="checkbox"/>
_____	Polycom Teleconferencing unit w/ line	\$300.00	\$350.00	_____
_____	ISDN (Radio Broadcast, Video conf.)	\$550.00	\$600.00	_____
_____	Internal Networking (per device)	\$150.00	\$200.00	_____
_____	IT Labor (VLANs, Firewalls, Assistance)	Per hour:	\$100.00	_____
Tax charged on I.T. Services.				
Long-distance per minute:		Pretax Subtotal: _____		
US - \$.35; Mexico - \$1.75; Canada - \$1.75;		Tax (5.6% or Exempt #): _____		
ISDN (US LD) - \$1.20; Dir. Asst. - \$2.50/call;		Subtotal I.T.: _____		
International - \$3.00				

D. Request for Installation

Install before:	Date / Time: _____	AM / PM
Remove after:	Date / Time: _____	AM / PM

E. Services Grand Total

--	--

F. WCD Payment Information

Wisconsin Center District • Attn: Exhibitor Services
 • 400 W. Wisconsin Ave. • Milwaukee, WI 53203 •
 Fax: (414) 877-0995 • Phone: (414) 908-6053
 • Email: ExhibitorSvc@wcd.org •

1. Check, M.O., Visa, Master Card, American Express, Discover Card #:
2. Credit Card Expiration Date:
3. Required Security Code:
4. Name on the Credit Card:

WCD Use Only

Date: _____	Total: _____
Initial: _____	Other: _____

WISCONSIN CENTER DISTRICT 2017 EXHIBITOR SERVICES ORDER FORM

Advance prices apply only to orders received by the WCD at least 14 days prior to the 1st day of the event scheduled exhibitor move-in.

Owners and Operators of the Wisconsin Center · UW-Milwaukee Panther Arena · Milwaukee Theatre

Mailing Address: Wisconsin Center District · 400 West Wisconsin Avenue · Milwaukee, WI 53203-2104

www.wcd.org · Main Tel.: (414) 908-6000 · Fax: (414) 877-0995 · Exhibitor Services: (414) 908-6053 · Email: ExhibitorSvc@wcd.org

Types of Exhibitor Booths

Line Booth - Booth adjacent to other booths, facing the aisle

Peninsula Booth - Booth at the end of a row of booths, an "endcap", adjacent to other booths behind it

Island Booth - A stand-alone booth, not directly adjacent to other booths

What is your booth type?

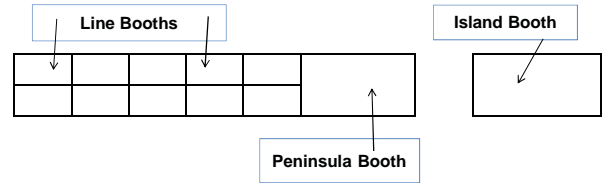

Floor Plan Examples (not to scale)

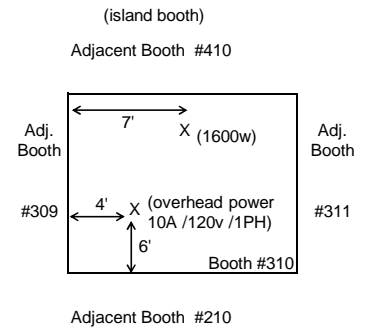
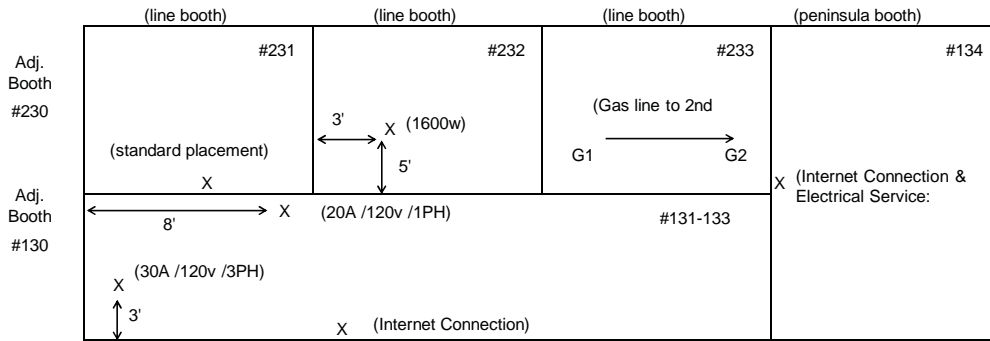

Exhibitor Floor Plan

Important elements of your Floor Plan to include:

- Mark service locations (i.e. electrical, mechanical, and information technology services)
- Indicate adjacent booth numbers and/or aisles
- Indicate your booth dimensions and measurements (i.e. 10 x 20 diagram below)
- PLEASE NOTE: If floor plan is not provided, services will be placed in the center-rear of your booth.**

What are your booth's dimensions?

x

Booth #:

Adjacent Booth # _____

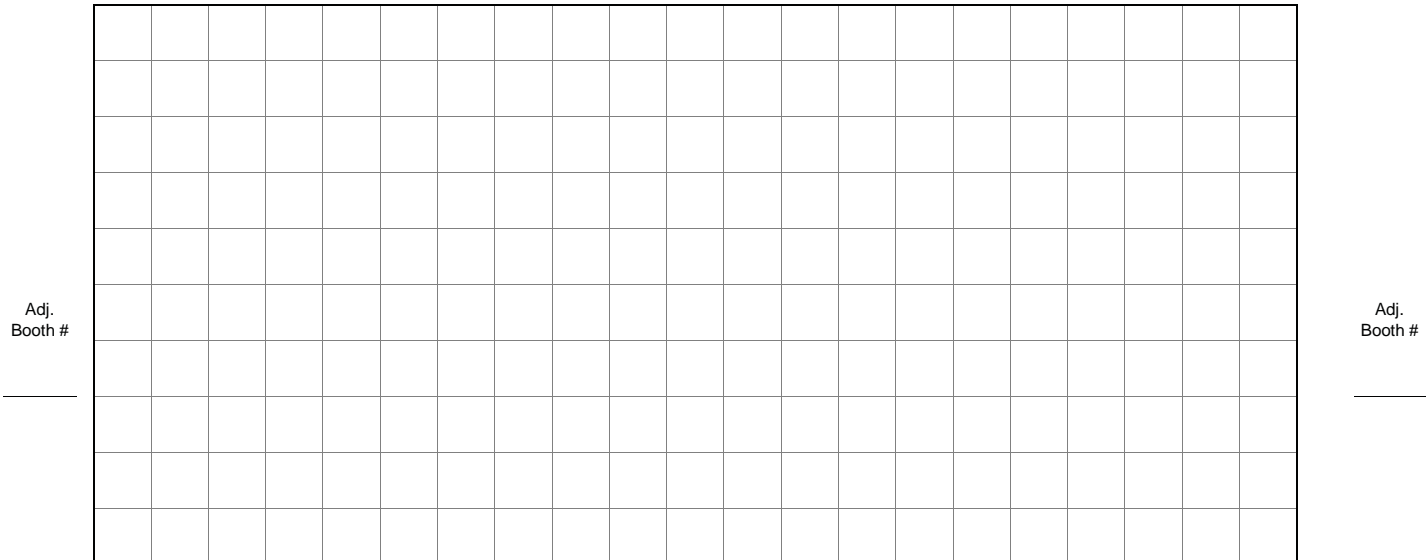

Adjacent Booth # _____

SERVICE CONDITIONS AND REGULATIONS

1. PAYMENT INFORMATION

- A. Company checks, money orders, Master Card, American Express, and Visa are accepted for payment, and subject to fund verification.
- B. To receive advance price, submit your order with full payment a minimum of fourteen (14) days prior to the first scheduled event Exhibitor move-in date. Orders submitted without full payment or received after the 14-day cut-off date are subject to standard prices.
- C. Arrangements for payment of services must be made before service is installed. Payment IN FULL must be rendered before end-of-show unless prior arrangements have been made with Exhibitor Services. Exception: labor, long distance toll charges, damaged, and/or missing equipment and other services/items may be billed after the event.

2. RATES AND LABOR CHARGES

- A. Rates quoted for all connections cover only the bringing of service to the booth in the most convenient manner, and DO NOT include connecting equipment to provided services.
- B. Special placement or relocation of service will result in a labor charge. Payment in full shall be rendered for such services before the close of the event unless prior arrangements have been made with Exhibitor Services.
- C. If services are ordered late (ie. during the event move-in), WCD does not guarantee services will be working before the event opens; discounts will not be given.
- D. All prices are based on current wage rates and are subject to change without notice.

3. INSTALLATION / DISCONNECTION OF SERVICES

- A. All order form information must be completed in full to avoid processing and installation delays.
- B. Orders will be processed and installations completed on a first-come, first-serve basis, or as we determine most convenient. Earliest orders will normally receive higher priority.
- C. All materials and equipment installed and provided by WCD for any of the services ordered shall remain WCD property and shall be disconnected and removed ONLY by WCD authorized personnel.
- D. Generally, service is up and running thirty (30) minutes before show start and turned off each night thirty (30) minutes after show close. Service will be working during show hours, and will not be working during the event move out. Special arrangements can be requested through WCD for early connect and/or late disconnect.
- E. The Exhibitor is responsible for replacement, repair costs, damages, etc. to equipment during rental period. The rental period starts when requested service or equipment is delivered or installed and ends when requested service or equipment is removed or disconnected. Any mishaps to equipment or services taking place during the rental period is your responsibility and will be charged to you appropriately.
- F. Client agrees not to resell, extend, bridge, or otherwise misuse utilities / services. WCD reserves the right to disconnect any client if they are found to have violated this usage agreement, or are deemed unsafe by WCD personnel.

4. CANCELLATIONS

- A. If cancellation occurs before installation and more than six (6) days prior to the first scheduled move-in day: 90% REFUND.
- B. If cancellation occurs before installation but six (6) days or less prior to the first scheduled move-in day: 75% REFUND.
- C. If cancellation occurs after installation or after the start of the first scheduled move-in day: NO REFUND.

5. SERVICE GUIDELINES

A. ELECTRICAL

- 1. Special voltage and/or other specialized power requirements must be received at least thirty (30) days prior to Exhibitor's scheduled arrival and move-in. Electrical Services Available: 120 volt, A.C.; 1 Phase 60 cycle, 208 volt, A.C., 1 Phase & 3 Phase 60 cycle; and 480 volt, A.C., 3 Phase 60 cycle.
- 2. 24-hour power will only be provided to those locations that have ordered and paid for 24-hour service. Otherwise, booth power will be turned on 30 minutes prior to each day's event opening and turned off 30 minutes after closing. Only WCD Electricians are permitted to service connections and overload protection to equipment.
- 3. Electrical Connections: Exhibitors may plug into purchased standard outlets and connect signal wiring (i.e. antennae, audio, video, and speakers) within a booth or between the Exhibitor's equipment with one booth. Only WCD Electricians are authorized to connect and disconnect power for utilities above 120v (ie. 208v and 480v power).
- 4. Location: Under NO circumstances shall anyone other than WCD Electricians make electrical connections to house power sources. Power requirements crossing aisles will not be installed unless approved by Show Management AND our Event Services Department. Obstructions blocking utility floor boxes are subject to relocation as necessary. WCD Electricians are authorized to cut floor coverings to permit installation of service unless otherwise directed. Standard wall, column, and permanent building electrical outlets are not a part of booth space and are not to be used by Exhibitors unless specified otherwise.
- 5. Prohibited Usage: Use of open clip sockets, latex or lamp cord wire, or unapproved duplex or triplex attachment plugs in exhibits are prohibited.
- 6. Equipment: All equipment must be properly tagged or marked with complete information as to the type and/or amount of current, voltage, phase, frequency, horsepower, etc. required. 120 volt cords must be of the 3 wire, grounded type. All exposed, non-current carrying metal parts of fixed equipment, which are liable to be energized, must be grounded. Exhibitors are responsible for all their displays and equipment conforming and meeting National Electric Code, and must be UL approved. WCD reserves the right to refuse connection to any Exhibitor whose equipment does not meet the National Electric, Federal, State and Local Safety codes. Special equipment requiring company engineers or technicians for assembly, servicing, preparatory work, and operation may be operated without WCD Electricians.
- 7. NOTICE: We cannot accept responsibility for voltage fluctuation or power failure due to temporary conditions beyond our control. For

your protection, we advise installing a surge protector on all your computers and other sensitive equipment. All electrical installations and connections to electrical service must be made by a WCD Electrician. We will not be responsible for damage or loss to any equipment, components, computer hardware, software or data, or injury to any person caused by the unauthorized installation of any equipment, connection to service, or wiring of any equipment by persons other than by WCD Electricians.

B. INFORMATION TECHNOLOGY (I.T.)

1. Prohibited: The purchase of an IP address is for ONE DEVICE ONLY (1-IP address per device). The use of routers, switches / hubs, DHCP, wireless LANs or other applications that allow the sharing of an IP address between multiple devices is PROHIBITED unless approved by the Wisconsin Center District Information Technology Department. Individuals in violation of this policy will be subject to the DISCONNECTION of their service.
2. Wireless (Wi-Fi) Internet Limitations and Vulnerabilities:
 - a. Wireless service is NOT for Mission-Critical uses and the WCD cannot guarantee it will work for these uses, such as the Registration area, or Presenters and Exhibitors doing demonstrations with internet service. WIRED internet connections should be used in such cases.
 - b. Wireless service is vulnerable to interference from other devices that transmit similar radio signals. WCD cannot guarantee that interference will not occur. (For this reason, if a Client would like to use any of their own Access Points (AP's), router, hubs, etc., they must be pre-approved by the WCD IT Staff at least 21 days in advance of the Event.) Otherwise, they could cause conflicts in the Client's own event, other Client's events, or the Convention Center's own Network. Any damage and expenses caused by this would be billed to the Exhibitor using unauthorized equipment.
 - c. WCD has a large amount of Internet bandwidth for Wi-Fi use, but the actual maximum bandwidth available depends on how many users are using the Internet at the same time, at any given moment.
 - d. Refunds will not be given for service issues found not to be the fault of WCD (such as using Wi-Fi for Mission-Critical uses listed above or misuse of the system).
3. Custom Video Services: If you would like to have your event visually recorded, have some video edited, or have other special video service needs, contact Tom Paul at (414) 908-6090.
4. Telephone Service: All telephone lines ordered will be provided with long distance dialing capabilities unless specifically noted on the order form.
5. NOTICE: The WCD is not responsible for damaged personal equipment and / or personal injury caused by the misuse of provided telecommunication and / or data service(s). Any tampering whatsoever with IT equipment (including, but not limited to, exhibit floor utility boxes, cabling, or rented equipment) at any time may result in the disconnection of ordered service(s) and or additional charges. The WCD is not responsible for personal injuries and/or equipment damage(s) that may occur as a result of this tampering.

C. MECHANICAL

1. WCD Engineer Service Work: Under NO circumstances shall anyone other than WCD Engineers make service connections, alter lines, install fittings, add branch connections, disconnect airlines to the original termination in booth, etc. Exhibitors who do not conform to this request are compromising the safety of others and will be charged labor fees or equipment and material loss fees accordingly.
2. Fittings/regulator: Exhibitors must furnish necessary fittings to connect to 1/4", 1/2" or 3/8" female (NPT) thread for water and air connections. NOTE: Pressure may vary. If pressure is critical, Exhibitors are to supply their own drier, regulator and/or pump and arrange for installation. For your protection we advise that WCD Engineers install the appropriate regulators on any connection requiring critical control of pressure, moisture content, etc.
3. Location: Services requiring crossing aisles will not be installed unless approved by Show Management AND our Event Services Department. Obstructions blocking utility floor boxes or other service access points are subject to relocation as necessary. WCD Engineers are authorized to cut floor coverings to permit installation of service unless otherwise directed. Most airlines will be installed from floor ports, minimal airlines will be flown above booth (contact Exhibitor Services for more information).
4. Equipment: All equipment must comply with all Federal, State and Local Safety Codes. Where applications require critical regulation of pressure, flow, or moisture content, the Exhibitor is responsible for supplying the necessary regulator, conditioner, etc. All equipment must be properly tagged or marked with appropriate information about requirements or tolerances regarding pressure, flow, capacity, rate-of-fill, and/or other factors pertinent to safety. We reserve the right to refuse connection to any Exhibitor whose equipment is deemed unsafe by a WCD Engineering Supervisor. All materials and equipment furnished by WCD for this service order shall remain WCD property and shall be disconnected and removed only by WCD Engineers at the close of the show. Tanks, drums, barrels, and other containers requiring water fill and drain exceeding 30 gallon capacity must be filled and drained by WCD Engineers and are subject to a service charge. We reserve the right not to fill any container that shows signs of leakage or is otherwise deemed inadequate by a WCD Engineering Supervisor. Containers showing signs of leakage will be drained by a WCD Engineer without prior notice.
5. NOTICE: Exhibitor assumes responsibility for any damage to Wisconsin Center District facilities caused by faulty Exhibitor equipment or negligent operation of Exhibitor equipment. We cannot accept responsibility for pressure fluctuations due to temporary conditions beyond our control. All installations and connections to mechanical services must be made by WCD Engineers. We will not be responsible for damage or loss to any equipment or components, or injury to any person caused by the unauthorized installation of any equipment, connection to service, or interconnection of any equipment by persons other than WCD Engineers. Removal of toxic waste or non-biodegradable waste is not permitted in drains. Removal of such waste is at Exhibitor's expense.
6. Portable air compressors and portable air tanks are not permitted.